

**EFFICIENT
SMART
SAFE**





Fitting Instructions Manual
E-Flex Easy Flexitank
with Pool



Rev04-231106

Liqua

Materials of Construction

Outer Cover		
PP Fabric 	Average Weight	240 g/m ²
	Colour	White
	Tensile Strength Warp	Dan/ 5 cm 240 Kg (ISO 13934-1)
	Tensile Strength Weft	Dan/ 5 cm 270 Kg
	Elongation at break - Weft	12% ±3 (ISO 13934-1)
	Elongation at break - Warp	14% ±3
	Density - Weft	48 tapes (/10cm) (ISO 7211/2)
	Density - Warp	80 tapes (/10cm)
Valve		
	Type	3" Male Cam-Lock
	Gasket / O-Ring	Food Grade NBR Polymer
	Raw material	Polypropylene + Stainless Steel
Cap	Type	3" screw in
	Raw material	Polypropylene
Restraining Belts		
Webbing 	Raw Material	Polypropylene Multifilament
	Average Weight	48 g/l/m
	Width	50 mm
	Tensile Strength Warp	1500 Kg (ISO 13934-1)
	Elongation	18 % (ISO 13934-1)

Materials of Construction

Inner Liner		
PE Film	Thickness	125 mic
	Total Layers	2
Mechanical Performance 	Dart Drop	1800 g (ASTM D1709)
	Tensile Strength	30 Mpa (MD) (ASTM D882)
		35 Mpa (TD)
	Seal Strength	≥30 Mpa (MD) (ASTM D882)
		≥35 Mpa (TD)
	Elongation at break	600% (MD) (ASTM D882)
		650% (TD)
	Tear Resistance	10 g/μm (MD) (ASTM D1922)
		22 g/μm (TD)
	Water Vapour Transmission Rate	<1 g/m ² .day (23°C;85% RH) (DIN 53122)
Oxygen Transmission Rate	1500 cc/m ² /day (23°C;75% RH) (ASTM D3985)	
Total System Oxygen Transmission Rate	Patented LiquA Design has zero Oxygen Transmission Rate	
Food Approval Legislations		
	FDA	21 CFR 177.1520 Polyolefin's
	EU	(EU) No 10/2011, 2018/213
Min/Max Ambient Temperature		
	Minimum	- 25°C
	Maximum	+ 70°C

Health and Safety Guidance

Risks and Controls

Potential Hazards	Controls	Safety Equipment to Use
Electricity	N/A	
Noise	N/A	
Manual handling	Operator should be trained in safe manual handling	
Traffic movements and slips/trips	The operator should wear appropriate PPE	PPE: Safety vest, hard hat, safety shoes, safety clothing, gloves, safety glasses
Fire	In case of fire, the operator should go to fire assembly point	
Harmful substances	The operator should wear appropriate PPE	Cut resistant gloves
Chemical exposure	The operator should wear appropriate PPE based on the transported cargo	Chemical resistant gloves and protective eyeglasses

Health and Safety Guidance

Training and Competency:

Ensure that individuals responsible for installation and operation are properly trained and competent to do so. This includes understanding the equipment, its specifications, and any associated safety protocols.

Safety Equipment and PPE:

Provide and use appropriate personal protective equipment (PPE) such as gloves, safety glasses, helmets, and respiratory protection when necessary.

Follow Manufacturer's Instructions:

Always follow the instructions for installation, operation, and maintenance. These instructions provide essential information for safe use.

Perform a pre-work risk assessment before starting any work. This risk assessment should involve below workplace risks ;

- Slips and trips
- Harmful substances
- Working at height
- Manual handling
- PPE usage
- Chemical exposure

Use proper PPEs based on the risks identified during the risk assessment.

Risk Assessment

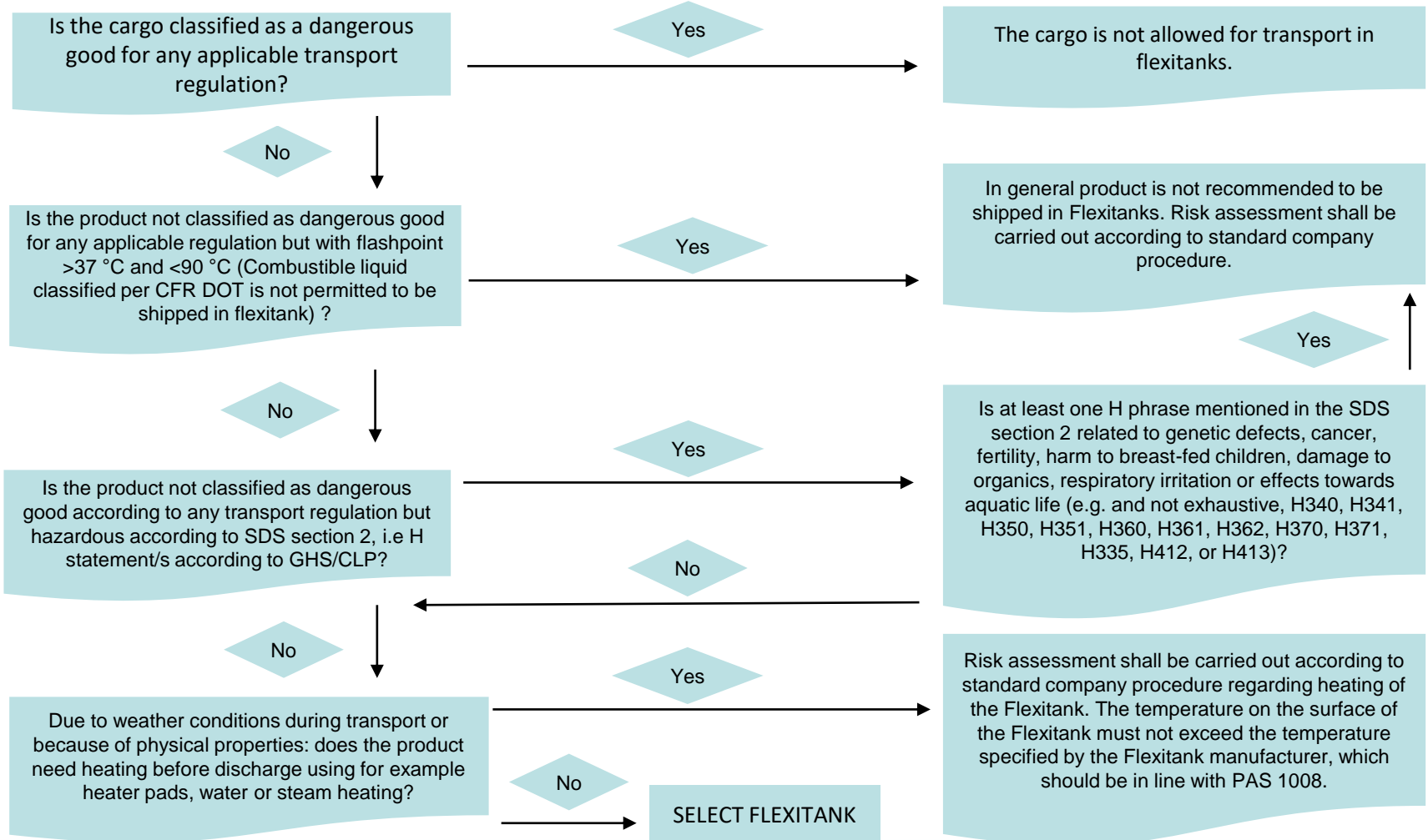

Container Selection

Ensure below criteria are met for the containers...

- No older than 5 years.
IMPORTANT: The above is the requirement set by Container Owners Assosiation. If not possible, ensure that below conditions are met.
- Manufactured according to ISO 668 norm.
- Weight tested to a minimum of 28,000kg.
- Clean, structurally sound and in excellent condition.
- No repairs on side walls and there no damage to the floor.
- Use food grade containers only, that are free of any odor.
- There are no insects, soil or contaminants that may cause customs issues at the destination.

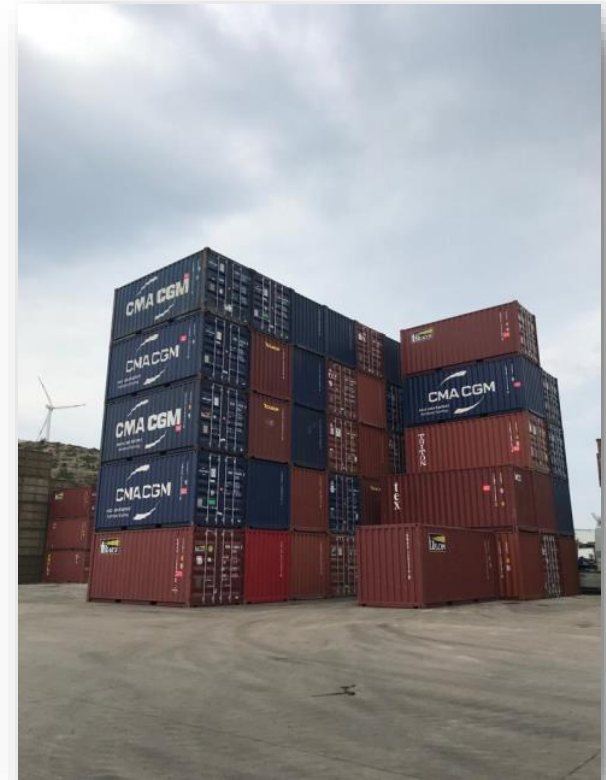

Container Selection

DO NOT use damaged or broken containers as shown below.

Broken or bulged containers can be rejected by the shipping lines at a later stage.



Bulged Container



Damaged Container

Container Selection

- Use standard containers ONLY designed according to ISO 668 international norm
- Ensure that containers have lashing rings on the floor



Container Selection

Central lug position may differ from one container to another. Ensure that there are lugs positioned at least 250 centimeters from the doors.

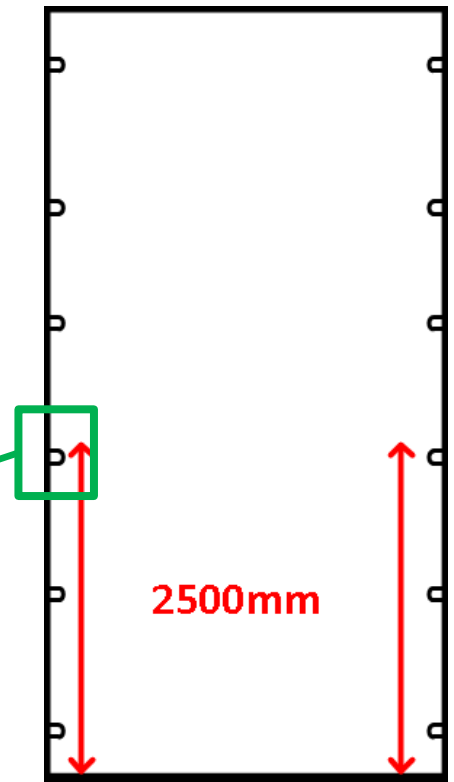

DOOR SIDE

Container Selection

- Sweep the container carefully with a broom.
- Ensure that the door bolts are silicon covered.



- Ensure that nails, sharp and rough objects that may damage or puncture the flexitank are removed.
- Cover uneven areas on the walls and on the floor with duck tape (thick tape).

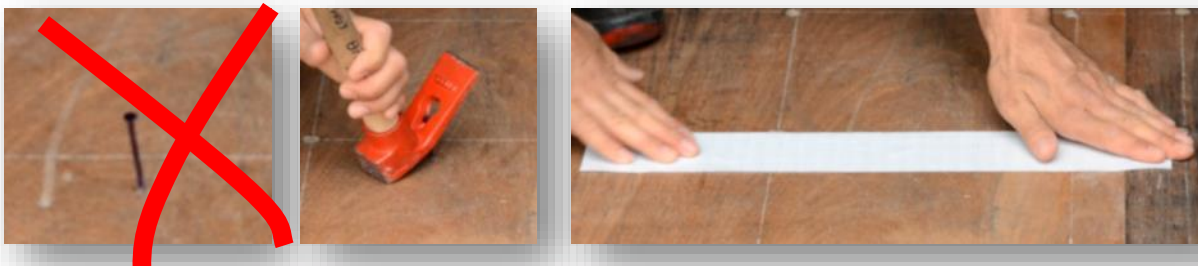

Container Lining

If the condition of the container is good and free of splinters, lining is not necessary. However, if you prefer to line the container, use a corrugated paper or if purchased, use the pp fabric provided by LiquA as shown below.



**EFFICIENT
SMART
SAFE**

Contents of the Box



Open the E-Flex box and ensure that the following are in the package:

1. E-Flex Easy Flexitank
2. Pool Liner (2 pieces)
3. Warning Labels
4. Adhesive Tape



**The box will be used for door protection.
Please preserve the box carefully!**

Positioning the Pool

Line the container walls with the pp lining fabric.



Lay out the pool on the floor of the container.



Positioning the Pool

- Lift up the folded part of the pool at the front wall end and tape it to the wall.
- Lift up the folded part at the sidewalls and tape them to the side walls until the central lashing rings which the flexitank belts are to be tied.

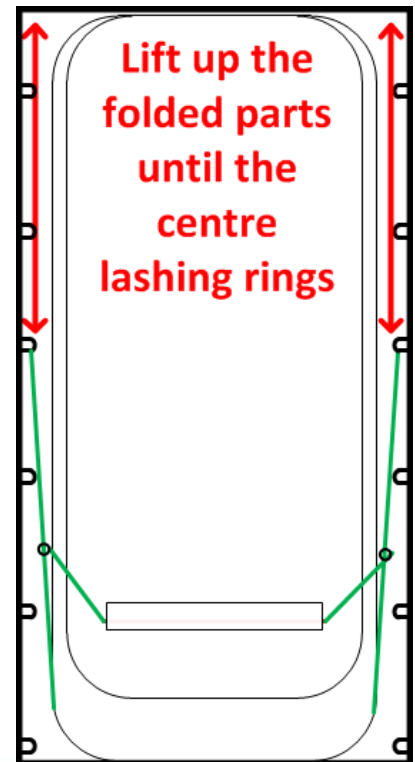

Positioning the E-Flex

- The distance between the E-Flex and the outer end of the container (NOT where the wooden floor begins) must be **20 cm**. Use the label for reference.
- Properly positioned Pool Liner at the door side, ends up at the front wall.

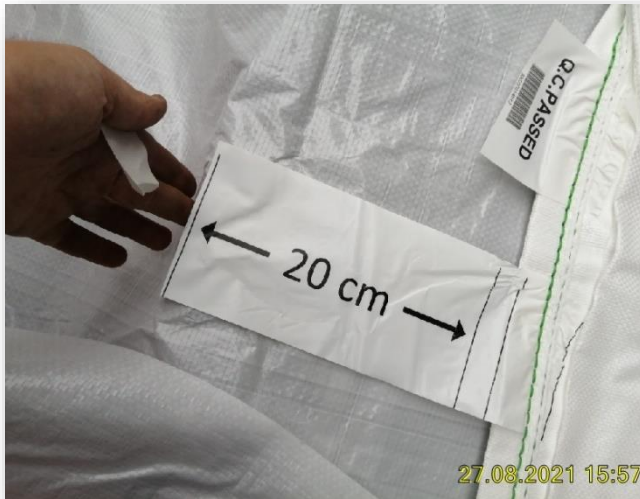

Positioning the E-Flex

- Position the E-Flex to the edge of the right door.
- Unroll the E-Flex.
- **DO NOT** step on the E-Flex while unrolling.



Positioning the E-Flex

- Pass the lashing belts through the pre-cuts marked on the pool in green color.



E-Flex Flexible Harness

- E-Flex must be tied to the lashing rings/lugs on the container floor in order to stabilize the flexitank during the transportation.

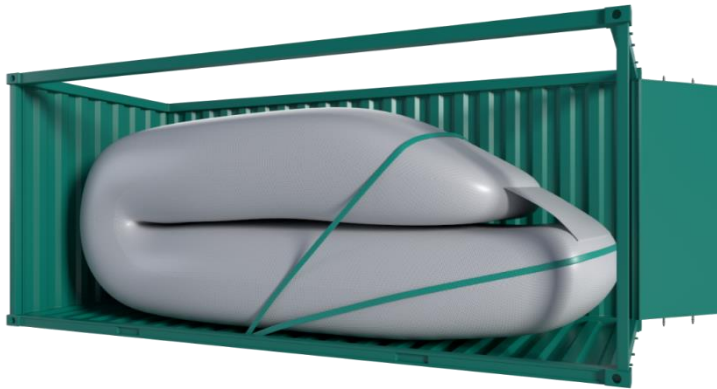

| E-Flex WARNING

- DO NOT WEAR SHOES AT ANY TIME YOU WALK ON THE E-FLEX. STEPPING ON THE E-FLEX WITH ANY TYPE OF SHOES MIGHT CAUSE MICRO HOLES AND LEAD TO LEAKAGE.
- MINIMIZE THE TIME YOU SPEND ON THE E-FLEX WHILE LASHING THE BELTS.
- THE ZONE AROUND THE VALVE AREA IS THE MOST DELICATE PART OF THE E-FLEX FOR ANY EXTERNAL DAMAGE. AVOID STEPPING AROUND THE VALVE AT ANY TIME.
- DO NOT BRING IN OR USE ANY SHARP OBJECTS WHILE YOU ARE INSIDE THE CONTAINER.



Belt Tying

Tie the lashing strap to the **CENTER** lug/lashing ring “taut but not tight”.

Central lug position may differ from one container to another. You may not find the lug positioned at the very center of the container. In any case, ensure that the harnessing belts are tied to a lug positioned at least 250cm far from the doors.

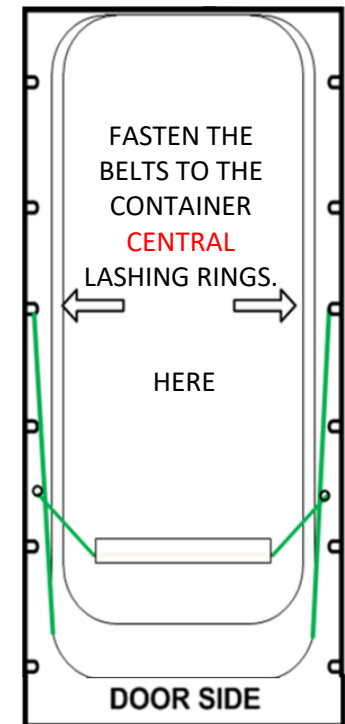

Belt Tying

IMPORTANT:

E-Flex is designed such that it will stand at least 15cm away from the doors after the filling. Loose or improper tying will inactivate the harnessing system and may cause the E-Flex to shift or move towards the doors.

Also, excessively tight or short belt tying may lead to capacity loss or damage.



ENSURE THAT BELTS ARE TIED TAUT BUT NOT TOO TIGHT.

Belt Tying

- **DO NOT** remove the pre-folding paper tapes.



Belt Tying

- Ensure that straps are tied to the **CENTER** lug/lashing rings!



Door Protection

- The flexible harness prevents any movement of the E-Flex. However to make sure that any sharp object or bolts on the door do not damage the flexitank, the carton box should be disassembled and used for protection.
- The box will be used as a door protector. Please break down the box as shown.



Door Protection

- Attach the boards to the door closing bars.



Check List

- Fill in the provided Check List and stick it to the door on the right-hand side.



| Warning

IMPROPER FITTING MAY CAUSE CAPACITY PROBLEMS, INNER LAYERS MAY GET STUCK AND STRETCH. THIS MAY CAUSE SEVERE LEAKINGS. ONLY TRAINED AND LICENSED OPERATORS ARE ALLOWED TO FIT OUR FLEXITANKS.

IF FITTING OPERATION HAS BEEN PERFORMED AT ANOTHER LOCATION, PLEASE ENSURE THAT THE E-FLEX HAS NOT MOVED DURING LOCAL TRANSPORTATION.

Warning Labels

- Stick the warning labels on the side walls and the doors of the container.
- Clean the surface of the container prior to sticking the label for better adherence.



I FAQ

What happens if I don't tie the harnessing belts?

You can consider the harnessing belts of E-Flex as similar to the seat belt in your car. If you don't fasten your seat belt and no accident occurs during your journey, you'll reach your final destination safely. However, in the event of an accident, the lack of seat belt may result in severe injury or even death.

Same principal is valid for E-Flex. If you don't secure the harnessing belts, everything may seem fine until you reach your final destination. However, in the case of an impact or accident, the flexitank may shift towards the doors, causing significant damage.

Additionally, when the container reaches its final destination, the flexitank may bulge out of the container when the consignee opens the door, potentially posing a hazard to operators.

Please ensure that harnessing belts are tied in accordance with LiquA instructions.

FAQ

Do I necessarily need to line every container with a protective material?

No...

We ask you to clean the container and inspect the container's surface for sharp objects very carefully. If you are confident about the condition of the container, lining is not necessary.

However, please note that wooden floors in containers may sometimes have splinters on the surface, which can potentially damage the flexitank. We recommend lining the containers with cardboard boards or the PP woven material provided by LiquA.

IMPORTANT: Lining the container **DOES NOT** guarantee protection for E-Flex against splinters or sharp objects. Take necessary precautions as if there were no lining materials.

FAQ

How important is it to position the E-Flex correctly on the container floor?

It is very important...

20ft containers have 32m³ free space in it and we use up to 27m³ of it. We ask you to position the flexitank 20cm from the outer edge of the container. If E-Flex is positioned wrongly towards the front wall, every 10cm will cause capacity loss of 1m³.

Also E-Flex stands on the floor as a two dimensional object. Layers get opened during the filling. Any mistake at the positioning of the E-Flex may cause inner layers to get trapped which may cause a rupture and leak.

Please follow the positioning instructions very carefully.

I FAQ

If I shorten the belts, untie the knots or position the flexitank in a different location can I reduce the flexitank capacity?

No.

- DO NOT change position of E-Flex on the floor of the container.
- DO NOT untie the knots on the flexitank.
- DO NOT tie the harnessing belts to a different location other than shown in this manual.
- DO NOT change the foldings.
- DO NOT remove the guiding paper tapes on the E-Flex.

On the contrary, changing any of the above not only do not change the capacity but also creates a hazard which may lead to a leak. E-Flex is designed to be assembled as easy as possible. Our production team has already folded, knotted, taped and prearranged everything for an easy fitting. Do not change any of the above. Just unroll the E-Flex, position correctly and tie the belts to the proper lashing rings/lugs.

Changing any of the above DOES NOT reduce the capacity. Fill E-Flex within the tolerances mentioned at the label and datasheet.

FAQ

If the container is not in good condition, shall I use metal bars to support the side walls?

No, E-Flex is a self supporting flexitank and it does not exert pressure to the side walls.

DO NOT use any metal bars under any circumstances.

It is not needed, it does not help, on the contrary, metal bars may create a hazard, damage the flexitank surface and cause a leak.

DO NOT use any material other than the ones you find in the E-Flex box.



Common Fitting Mistakes



DO NOT change the foldings



The distance must be 20 cm between the flexitank and the outer end of the container



The belt tying must be 'taut but not tight'

Ready For Filling

**EFFICIENT
SMART
SAFE**



Compatibility

Product SDS needs to be compatible with our raw materials polypropylene, polyethylene and stainless steel.

Some of the Cargoes that are transported in the E-Flex Flexitank

- Wine
- Juice
- Milk
- Palm Oil
- Fish Oil
- Edible Oil
- Water
- Syrups
- Non-hazardous Chemicals

EFFICIENT
SMART
SAFE

I Coupling

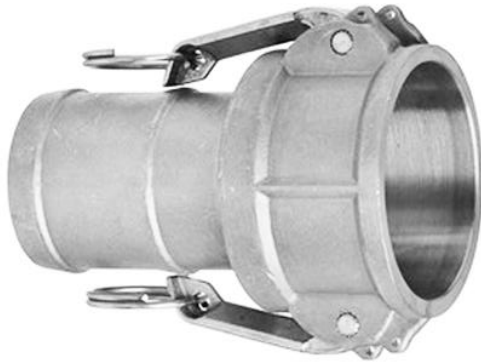

Our standard valve is 3" male camlock.

You will need to have a **3" female cam-lock** coupling. (DIN EN 14 420-7)

Upon request, 2" reductor is available.

WARNING

BEFORE COUPLING, **DO NOT** THROW THE HOSE OVER THE FLEXITANK

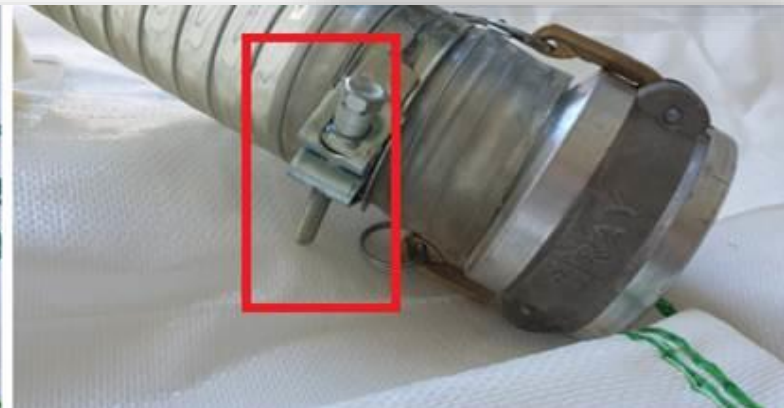
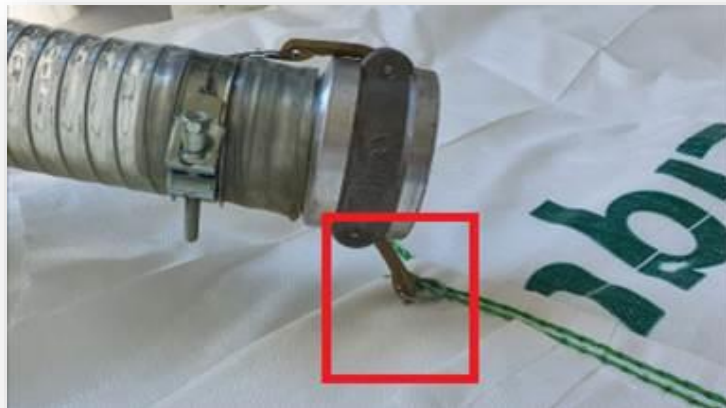

Coupling



1. Open the hygiene seal.
2. Remove the dust cap.
3. Couple the hose.
4. Compress the latch.
5. Rotate the arm.
6. Unroll the bonnet.

I Coupling

Lock the valve from the camlock lugs with a cable tie for a safer valve connection.



Coupling

Place fabric or cardboard underneath the hose to protect the flexitank during the filling operation.



Filling

- Start loading the E-Flex.
- **WARNING:** Ensure that the start up pumping speed does not exceed 300 lt /min until the E-Flex rises to an approximate height of 30cm (roughly the first 2-3,000 liters) , then increase the speed up to 600lt/min. Please ensure that the filling stations follow this instruction carefully.
- Ideal filling time is one hour...
- **WARNING:**
TEMPERATURE LIMITS
Product temperature Min -20° C Max +65° C



Filling

- Ensure that you have chosen a lightweight filling hose.
- Couple the hose to the valve.
- Make sure that protective plastic cover `bonnet` is unrolled. It will avoid possible contamination due to spillage while decoupling.



Supporting the Filling Hose

- Support the hose from the right point. Ensure that the hose is NOT put under any stress at any point in time during the filling period.

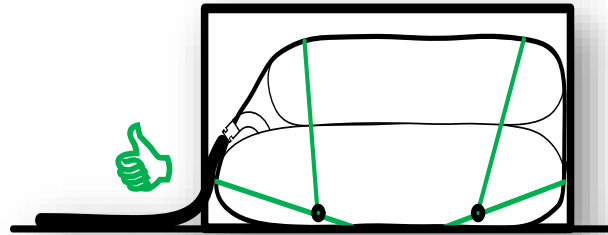
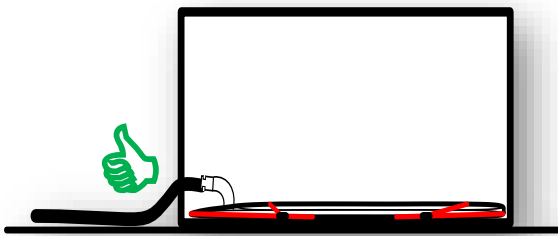

- Hose support must be done very carefully. Support shall not create any torsion/stress over the valve.

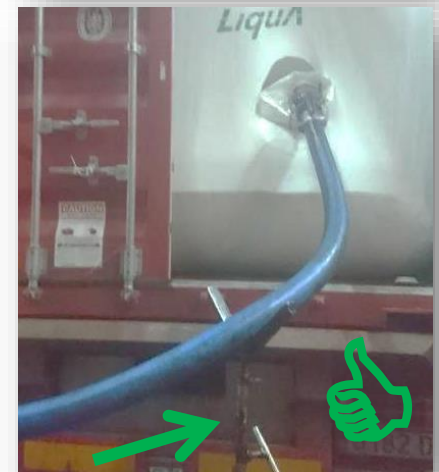
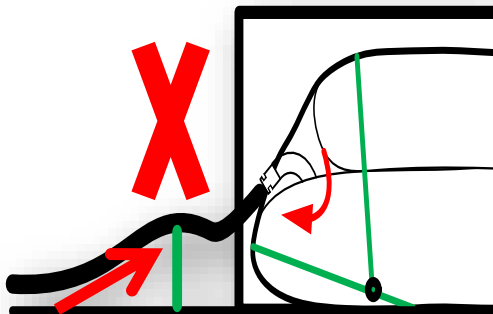

Supporting the Filling Hose

- Our valve is not static. It raises up during the filling. Therefore, if the filling hose is supported with a tripod or something similar, ensure that the support point is being changed periodically during the entire filling.



- If hose support is not being used, ensure that the hose does not exert any pressure to the valve. Ideal standing is shown at the picture.

Supporting the Filling Hose

- Ensure that the hose is not too short and not too stiff. Prevent the hose from pulling out the flexitank towards the doors.

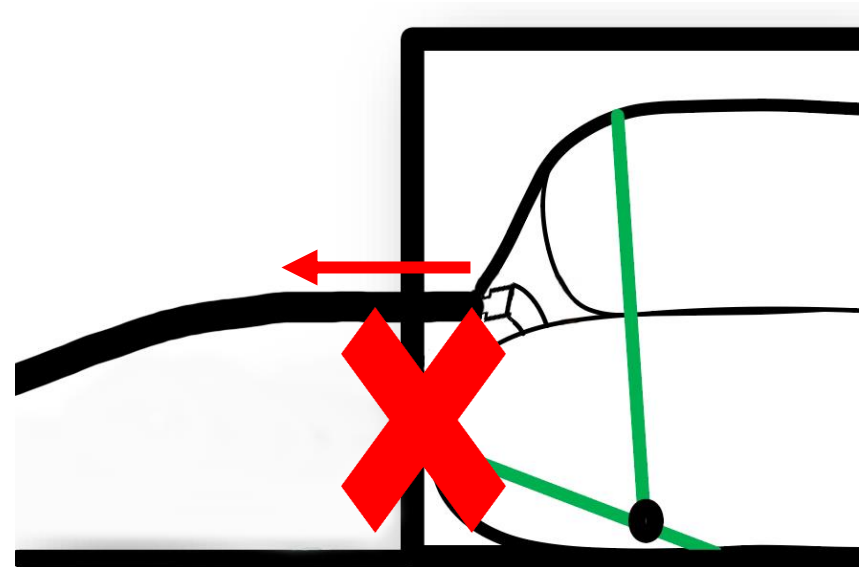

Filling



After Loading;

1. Close the valve.
2. Remove the hose.
3. Fasten the dust cap

| Bonnet Closure

E-Flex has two protective bonnets around the inlet to prevent contamination and to act as secondary containment in case of an incident.

Ensure that Bonnet is well tied according to our instructions.



Bonnet Closure



The Protective Bonnet has two individual layers of plastic film.

Both layers must be tied **separately**.

1. Push back the outer bonnet to expose the inner bonnet for easy operation.
2. Twist the full length of the inner bonnet. Ensure that minimum amount of air/space is left in the bonnet.
3. Make a tight knot, as close as possible to the valve.
4. Unroll the outer bonnet.
5. Twist the full length of the inner bonnet. Ensure that minimum amount of air/space is left in the bonnet.
6. Make a tight knot, as close as possible to the valve.

Check List

- Fill in the provided Check List after loading.



I FAQ

What happens if the E-Flex is loaded faster than the instructions?

If the cargo is filled in high speed, the layers of our E-Flex may not open easily, product may get trapped in between the layers and cause a puncture.

Ensure that the start up pumping speed does not exceed 300 lt /min until the E-Flex rises to an approximate height of 30cm (roughly the first 2-3,000 liters) , then increase the speed up to 600lt/min. Please ensure that the filling stations follow this instruction carefully.

How important is it to support heavy hose during the filling?

The filling hose must be supported very carefully. Support shall not create any torsion/stress over the valve. Our valve location is not static during the filling. Therefore, the support location should be changed when the hose starts to put stress on the valve.

I FAQ

What happens if I overload or under load the E-Flex than its nominated capacity?

Fill E-Flex within the tolerances stated at the datasheet and/or on the label.

Exceeding the upper limit may cause severe damage on E-Flex and flexitank may break with a total loss outcome.

If you under load the E-Flex less than the bottom limit, lack of cargo in the flexitank may cause severe surge in the flexitank during the transportation.

Ensure that the amount of cargo in the E-Flex is within the tolerances.

IMPORTANT: We deliver our flexitanks airtight. Ensure that you do not pump in air into the flexitank. The volume of air in the flexitank cannot be predicted; you might be overloading the flexitank unintentionally due to the volume of air.

Common Filling Mistakes



Fill the flexitank according to the tolerances stated at the label. Under loading is not permitted.



Use the flexitank bonnet to avoid possible contamination



Hose support shall not create any torsion/stress over the valve

Common Filling Mistakes

Below is a photograph taken after a postmortem. As you may see, the inner polyethylene layers were melted at three individual spots, marked in green color.

If your cargo is warmer than 35°C;

- Measure the temperature ex-hose, meaning that measure the temperature of the cargo inside the filling hose. The temperature on the tank and the cargo in the hose can be different. Take the cargo temperature at the hose into consideration.
- Preferably, DO NOT pump the first few liters in the hose into to the flexitank
- ALWAYS, make slow filling, 300 liters per minute.



| Action for Leakage, Overspill and Bulging During the Filling

In the event of issues such as leakage, overspill, or excessive container wall bulging when using a flexitank, it's crucial to respond promptly and safely:

- **Prioritize Safety:** Ensure all personnel wear appropriate PPE.
- **Stop the Flow:** Shut off valves or connections to stop further discharge.
- **Contain:** Use containment materials to prevent the spread of spilled material.
- **Identify the Source:** Determine the cause and location of the issue.
- **Isolate the Area:** Close off or seal affected sections if possible.
- **Report:** Notify relevant personnel and follow communication protocols.
- **Contain and Clean-Up:** Safely clean up with suitable materials and equipment.
- **Repair or Replace:** Assess and address the cause, making repairs or replacements.
- **Investigate:** Determine the root cause and maintenance or procedural changes needed.
- **Document:** Maintain detailed records of the incident and actions taken.
- **Regulatory Compliance:** Ensure compliance with relevant regulations and standards.
- **Review and Improve:** Analyze the incident for opportunities to enhance safety procedures.

| Discharging

**EFFICIENT
SMART
SAFE**



Positioning the Container

Ensure that the front of the container is in a higher position compared to the back/door side, so that it will have the necessary slope to facilitate the discharge. Interval of **15cm** is sufficient.

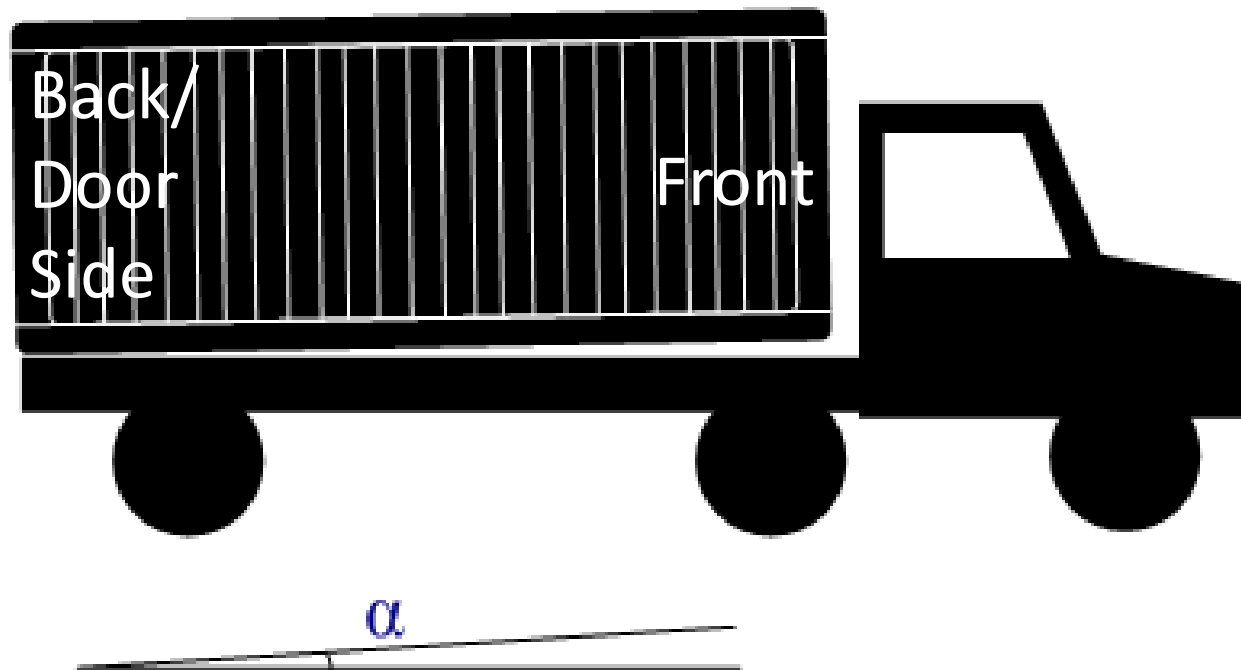

EFFICIENT
SMART
SAFE

I Coupling

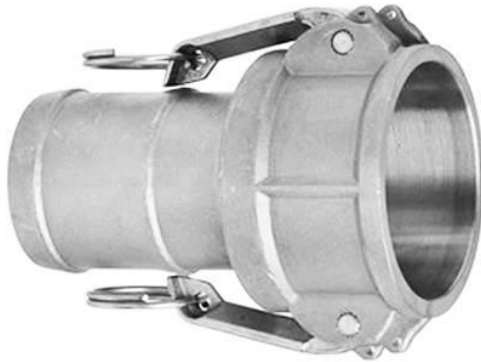

Our standard valve is 3" male camlock.

You will need to have a **3" female cam-lock** coupling. (DIN EN 14 420-7)

Upon request, 2" reductor is available.

Coupling



1. Remove the dust cap.
2. Couple the hose.
3. Compress the latch.
4. Rotate the arm.
5. Unroll the bonnet.

Discharging

- Start discharging the E-Flex.
- Do not suspend the hose.
- Use a pump to decant the flexitank.
- **WARNING:** We recommend the discharging speed to be set to approximately 300Lt per minute level at the very last 3-4,000Lt. Strong pumps may suck the inner layers of our flexitank which may cause a blockage at the valve. Reducing the discharging speed avoids problems as such.



Supporting the Hose

- Support the hose from the right point. Ensure that the hose is NOT put under any stress at any point in time during the entire discharging period.

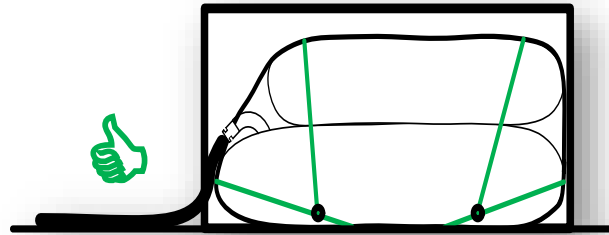

- Hose support must be done very carefully. Support shall not create any torsion/stress over the valve.

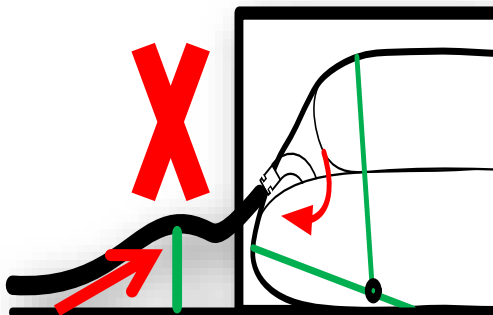

**EFFICIENT
SMART
SAFE**

Flexitank Lashing Straps

When the discharging is completed, untie/cut the lashing straps (shown with red arrows) fixed to the container lashing rings.



Discharging

After pumping all the product out, pull both sides of the E-Flex to the center.



Discharging

Roll-up the E-flex starting from the front/nose side of the container, pushing the liquid towards the valve.



**EFFICIENT
SMART
SAFE**

Discharging

The E-Flex should be empty and ready for recycling at this point.



Incident Management

In the unlikely scenario of an incident, our field technicians will provide support for:

Comprehensive Tracking:

Our field technicians are ready to assist you in achieving complete traceability of the incident.

Thorough Investigation of Underlying Causes:

We are equipped to conduct a deep analysis to uncover the fundamental reasons behind the incident.

Detailed Record-Keeping for Exceptions:

Our team will diligently maintain records of any exceptional occurrences for documentation and analysis purposes.

Corrective Action

We are prepared to take proactive steps to rectify the situation and arrange corrective actions to prevent reoccurrence.

Please be assured that our global network of field technicians stand ready to provide support and expertise in the event of any unforeseen circumstances.

Training

**EFFICIENT
SMART
SAFE**



CERTIFICATE

We are pleased to present this certificate confirming the below operators compiled our training program for fitting and filling our E-FLEX.

We hereby confirm that

▪

from company

located in

At LiquA, we not only supply manuals to operators but also deliver comprehensive training directly in the operational areas related to our flexitanks by our certified technicians. We also provide certification for this training.



www.liquatrans.com | info@liquatrans.com
LiquA Europe SLU
Calle Jose Aguirre 40, Piso 3 Valencia, España
CP- 46001
+34 960 011 520

**EFFICIENT
SMART
SAFE**

**EFFICIENT
SMART
SAFE**

LiquA

THANK YOU

LiquA Europe
Calle José Aguirre 40, Piso 3 Valencia España
CP: 46011
+34 91 1238506
LiquA Fabrika
Atabey Cd. No 28 Kat 1 Çekmeköy 34794 İstanbul
Türkiye
+90 216 312 8660

www.liquatrans.com

| info@liquatrans.com